

# Modular cartridge valves type LIQV and LIDD

Flow control, ISO 7368 sizes 16 ÷ 63

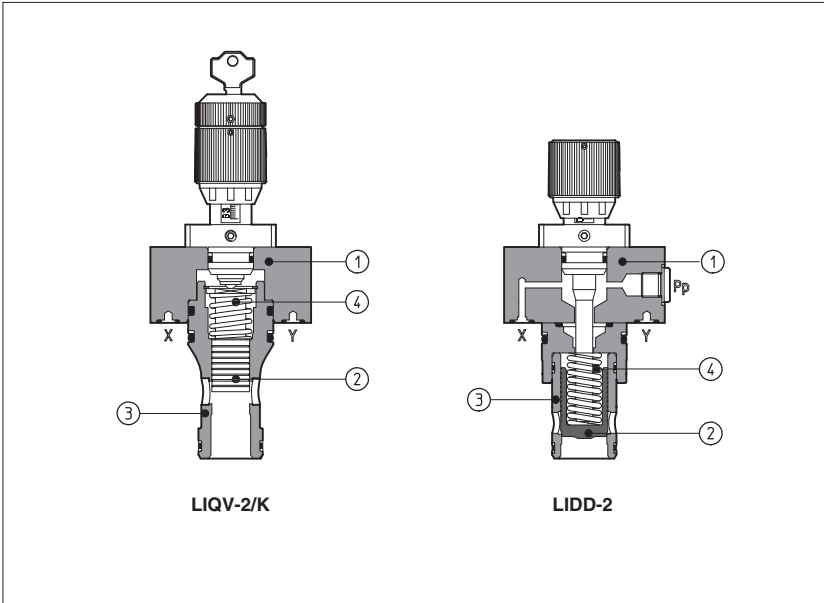

LIQV and LIDD are flow control valves composed by a 2 way cartridge housed in a standard recess and by a functional "cover" ①.

The cartridge is composed by a spool (for LIQV) or poppet (for LIDD) ② sliding into a drilled sleeve ③; the position of the spool or poppet, corresponding to the regulation of the valve, is manually set on the cover; cracking pressure value depends on poppet spring.

These valves are available in standard sizes 16 to 63 according to ISO 7368 (DIN 24342).

Flow up to 3500 l/min at  $\Delta p = 6$  bar, pressure up to 350 bar.

## 1 MODEL CODE FOR COVERS

<b>LI</b>	<b>QV</b>	-	<b>1</b>	/	*	<b>**</b>	/*
Cover according to ISO 7368							
Flow control valve: <b>QV</b> = with manual setting <b>DD</b> = normally closed with stroke limiter							Seals material: - = NBR <b>PE</b> = FKM <b>BT</b> = HNBR
Size: <b>1</b> = 16 <b>4</b> = 40 (*) <b>2</b> = 25 <b>5</b> = 50 (*) <b>3</b> = 32 (*) <b>6</b> = 63 (*) (*) only for LIDD						Series number	
For model code of spool or poppet, see section ③							Options: see section ④

## 2 HYDRAULIC SYMBOLS AND CHARACTERISTICS

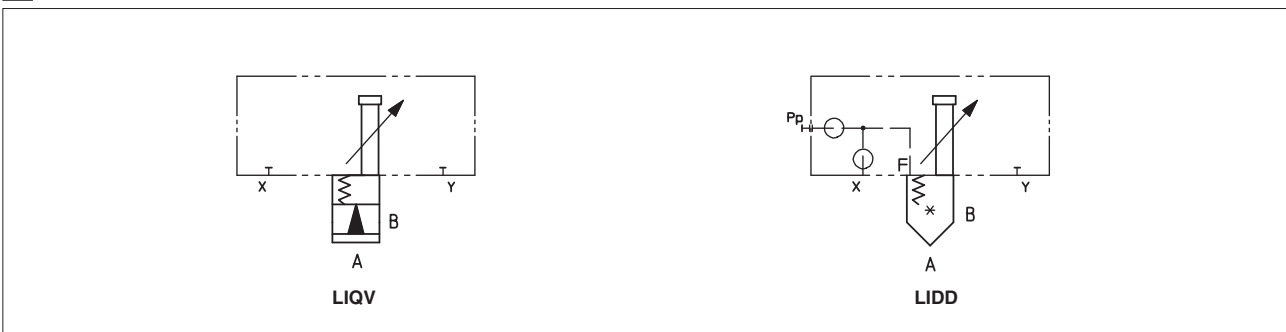

Covers see section ①	LIQV-1			LIQV-2			LIDD																										
	290	490	490	32						33						42						43											
Spool see section ③, ④																																	
Poppet see section ③, ④	-	-	-																														
Size	16	16	25	16	25	32	40	50	63	16	25	32	40	50	63	16	25	32	40	50	63	16	25	32	40	50	63	16	25	32	40	50	63
Max flow at $\Delta p = 6$ bar [l/min]	60	180	400	180	430	670	1400	2200	3500	160	330	530	1100	1700	2600	170	380	560	1300	2000	2800	130	300	480	940	1500	2200						
Max pressure [bar]	350 bar at port A, B, X																																

**3 MODEL CODE FOR SPARE SPOOLS AND POPPETS**, see section 4 for function

<b>SC LI</b>	-	<b>16</b>	<b>43</b>	<b>1</b>	<b>**</b>	<b>/*</b>
Cartridge according to ISO 7368				Series number		Seals material: - = NBR <b>PE</b> = FKM <b>BT</b> = HNBR
Size, the same of relevant cover: <b>16</b> = 16 <b>40</b> = 40 (*) <b>25</b> = 25 <b>50</b> = 50 (*) <b>32</b> = 32 (*) <b>63</b> = 63 (*) (*) only for LIDD		Type of poppet (only for LIDD): <b>32, 33</b> (size 16...63) <b>42, 43</b> (size 16...63) = as 32, 33 but with dumping nose		Spring cracking pressure (only for poppet): <b>1</b> = 0,3 bar for poppet 32, 42 <b>1</b> = 0,6 bar for poppet 33, 43 <b>2</b> = 1,5 bar for poppet 32, 42 <b>3</b> = 3 bar for all poppets <b>6</b> = 6 bar for all poppets		
Type of spool (only for LIQV): <b>290</b> = for LIQV-1 <b>490</b> = for LIQV-1 and LIQV-2						

**4 TYPICAL FUNCTIONS OF SPOOL AND POPPETS**

Code of spool or poppet	290 - 490	32	33	42	43
Functional sketch (Hydraulic symbol)					
Typical section					
Area ratio (1)	1 : 1	1 : 1,1	1 : 2 for size 16, 25 1 : 1,6 for size 32 ÷ 80	1 : 1,1	1 : 2 for size 16, 25 1 : 1,6 for size 32 ÷ 63

(1) It is the ratio of the area on which the main pressure of the circuit is applied to the area on which the pilot pressure is applied.

**5 MAIN CHARACTERISTICS OF FLOW CONTROL CARTRIDGE VALVES TYPE LIQV, LIDD**

Assembly position / location	Any position
Subplate surface finishing	Roughness index Ra 0,4 - flatness ratio 0,01/100 (ISO 1101)
Ambient temperature	Standard execution = -30°C ÷ +70°C; /PE option = -20°C ÷ +70°C; /BT option = -40°C ÷ +70°C
Fluid	Hydraulic oil as per DIN 51524 . . . 535; for other fluids see section 11
Recommended viscosity	15 ÷ 100 mm <sup>2</sup> /s at 40°C (ISO VG 15 ÷ 100)
Fluid contamination class	ISO 4406 class 21/19/16 NAS 1638 class 10, in line filters of 25 µm (β <sub>25</sub> ≥ 75 recommended)
Seals, recommended fluid temperature	NBR seals (standard) = -20°C ÷ +60°C, with HFC hydraulic fluids = -20°C ÷ +50°C FKM seals (/PE option) = -20°C ÷ +80°C HNBR seals (/BT option) = -40°C ÷ +60°C, with HFC hydraulic fluids = -40°C ÷ +50°C

**6 OPTIONS**

Only for LIQV:  
**/K** = with lock key for setting knob.  
Only for LIDD:  
**/E** = with external attachments X and underneath port X supplied plugged;  
**\*\*\*** = Calibrated plugs different from standard ones. LIDD covers in standard executions are not equipped with restrictors in the pilot channels.  
When ordering covers equipped with restrictors, it must be indicated at the end of the model code:

<b>LIDD</b>	-	<b>1</b>	<b>/E</b>	<b>X</b>	<b>06</b>
Channel where the restrictor has to be provided: <b>X</b> = channel X					Size of the throttling hole in ten of millimeters: <b>05</b> = 0,5 mm <b>10</b> = 1 mm <b>06</b> = 0,6 mm <b>12</b> = 1,2 mm <b>08</b> = 0,8 mm <b>15</b> = 1,5 mm

**7 DIAGRAMS OF SPOOLS**

**7.1 Regulation diagram**

- 1** = SC LI-16290
- 2** = SC LI-16490
- 3** = SC LI-25490

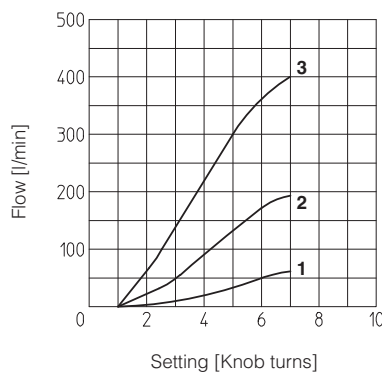

**7.2 Operation diagram**

- 4** = SC LI-16290
- 5** = SC LI-16490
- 6** = SC LI-25490

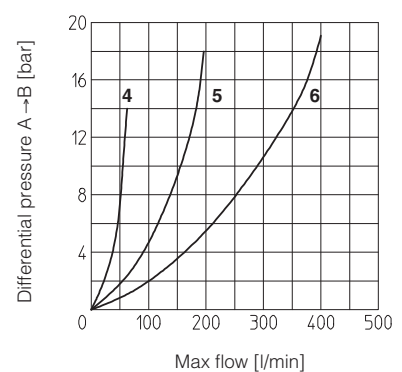

**8 DIAGRAMS OF POPPETS**

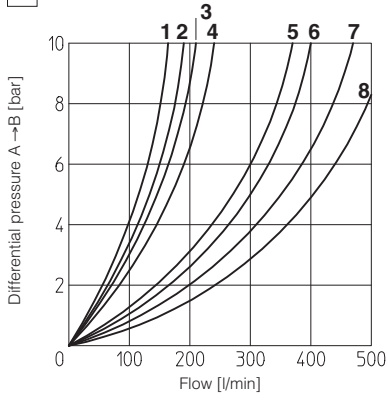

- 1 = SC LI-1643      5 = SC LI-2543
- 2 = SC LI-1633      6 = SC LI-2533
- 3 = SC LI-1642      7 = SC LI-2542
- 4 = SC LI-1632      8 = SC LI-2532

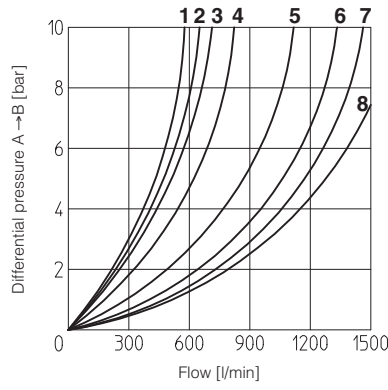

- 1 = SC LI-3243      5 = SC LI-4043
- 2 = SC LI-3233      6 = SC LI-4033
- 3 = SC LI-3242      7 = SC LI-4042
- 4 = SC LI-3232      8 = SC LI-4032

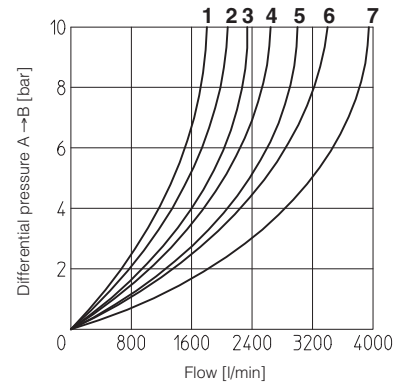

- 1 = SC LI-5043      5 = SC LI-6333
- 2 = SC LI-5033      6 = SC LI-6342
- 3 = SC LI-5042      7 = SC LI-6332
- 4 = SC LI-5032      SC LI-6343

**9 RECESS DIMENSIONS [mm]**

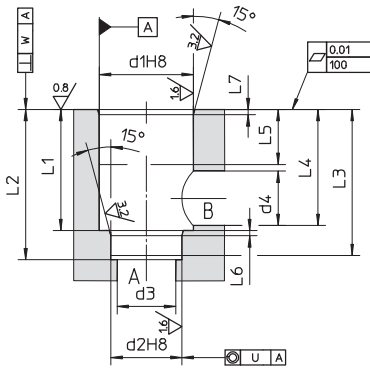

Sizes	Ø d1	Ø d2	Ø d3 max	Ø d4 max	L1	L2	L3	L4 max	L5	L6	L7	U	W
16	32	25	16	22,5	43 <sup>+0,1</sup> <sub>0</sub>	56 <sup>+0,1</sup> <sub>0</sub>	54	42,5	20	2	2	0,03	0,05
25	45	34	25	27	58 <sup>+0,1</sup> <sub>0</sub>	72 <sup>+0,1</sup> <sub>0</sub>	70	57	30	2,5	2,5	0,03	0,05
32	60	45	32	38,5	70 <sup>+0,1</sup> <sub>0</sub>	85 <sup>+0,1</sup> <sub>0</sub>	83	68,5	30	2,5	2,5	0,03	0,1
40	75	55	40	54,5	87 <sup>+0,1</sup> <sub>0</sub>	105 <sup>+0,1</sup> <sub>0</sub>	102	84,5	30	3	3	0,05	0,1
50	90	68	50	62,5	100 <sup>+0,1</sup> <sub>0</sub>	122 <sup>+0,1</sup> <sub>0</sub>	117	97,5	35	3	3	0,05	0,1
63	120	90	63	87	130 <sup>+0,1</sup> <sub>0</sub>	155 <sup>+0,1</sup> <sub>0</sub>	150	127	40	4	4	0,05	0,2

**10 COVER INTERFACE DIMENSIONS [mm]**

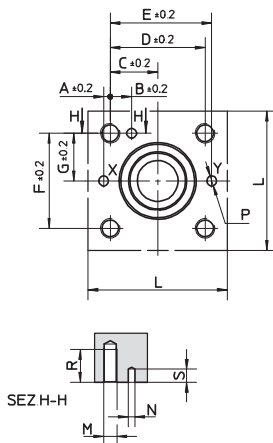

Sizes	A	B	C	D	E	F	G	L min	M	ØN	ØP max	R	S max
16	2	12,5	23	46	48	46	23	65	M8	4	4	22	8
25	4	13	29	58	62	58	29	85	M12	6	6	30	8
32	6	18	35	70	76	70	35	102	M16	6	8	38	8
40	7,5	19,5	42,5	85	92,5	85	42,5	125	M20	6	10	46	8
50	8	20	50	100	108	100	50	140	M20	8	10	46	8
63	12,5	24,5	62,5	125	137,5	125	62,5	180	M30	8	12	66	8

11 LIQV COVER DIMENSIONS [mm]

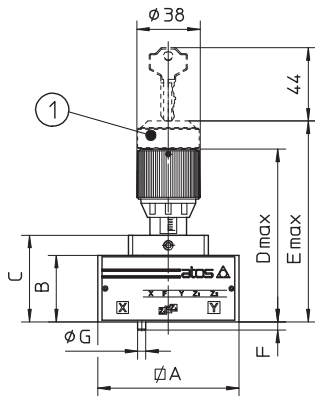

① /K version wit knob locking key

Covers	A	B	C	D max	E max	F	G	Seals	Fastening bolts (1)	Tightening torque [Nm]	Weight [Kg]
LIQV-1	65	40	52	104	121	4	3	2 OR 108	Nr. 4 M8x45	35	1,7
LIQV-2	85	40	52	104	121	6	5	2 OR 108	Nr. 4 M12x45	125	2,1

(1) Hexagon socket head screw according to DIN 912 class 12.9

12 LIDD COVER DIMENSIONS [mm]

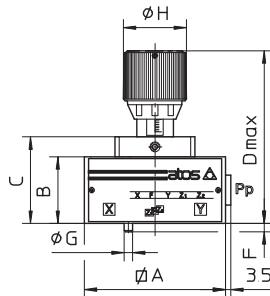

LIDD (dim. 16...40)

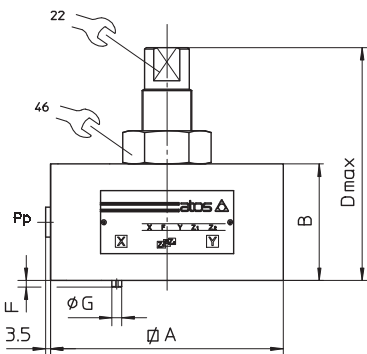

LIDD (size 50 ÷ 63)

Covers	A	B	C	D max	F	G	H	Port Pp	Seals	Fastening bolts (1)	Tightening torque [Nm]	Weight [Kg]
LIDD-1	65	40	52	104	4	3	38	G1/4	2 OR 108	Nr. 4 M8x45	35	2
LIDD-2	85	40	52	104	6	5	38	G1/4	2 OR 108	Nr. 4 M12x45	125	2,4
LIDD-3	100	50	75	156	6	5	50	G1/4	2 OR 2043	Nr. 4 M16x55	300	2,8
LIDD-4	125	60	85	166	6	5	50	G1/4	2 OR 2050	Nr. 4 M20x70	600	6,7
LIDD-5	140	70	-	140	4	6	-	G1/4	2 OR 2050	Nr. 4 M20x80	600	9,8
LIDD-6	180	80	-	151	4	6	-	G3/8	2 OR 2056	Nr. 4 M30x90	2100	17,5

(1) Hexagon socket head screw according to DIN 912 class 12.9